

24" Flush Handle Dishwasher 500 Series- Stainless steel SHP65T55UC



Features and Benefits

Key Features

- 44 dBA- Quietest Brand
- 3rd Rack for Additional Loading Capacity
- InfoLight® Beams on Floor to Indicate Dishwasher is Running
- RackMatic® on Upper Rack - 3 Height Adjustments and Up to 9 Possible Rack Positions
- AquaStop® Leak Protection Works 24/7

Design

- Full Size Stainless Steel Tall Tub Installs Perfectly Flush
- 3rd Rack for Additional Loading Capacity
- 16 Place Setting Capacity
- LED Remaining Time Display
- RackMatic® on Upper Rack - 3 Height Adjustments and Up to 9 Possible Rack Positions

Performance

- 44 dBA- Quietest Brand
- 5 Programs and 5 Options
- Detergent Tray Optimizes Detergent Dissolving
- Load Size Sensor Automates Wash Temperature
- Sanitize Option Eliminates Bacteria and Enhances Drying Results
- ExtraShine™ Option Enhances Shine and Drying Results of your Dishes

Efficiency

- 259 kwh/yr - Energy Star®
- Half Load Option for Small Loads

Convenience

- InfoLight® Beams on Floor to Indicate Dishwasher is Running
- 24 h Delay Start Timer



Notes: All height, width and depth dimensions are shown in inches. *Please refer to installation instructions prior to making cutout. BSH reserves the absolute and unrestricted right to change product materials and specifications, at any time, without notice. Consult the product's installation instructions for final dimensional data and other details. Applicable product warranty can be found in a accompanying product literature or you may contact your account manager for further details.

For more information on our entire line of products, go to boschappliances.com or call 1-800-944-2904.
Copyright ©2013 BSH Home Appliances Corporation. All rights reserved. Bosch is a registered trademark of Robert Bosch GmbH.

Litho Date: 12/2013



24" Flush Handle Dishwasher 500 Series- Stainless steel SHP65T55UC

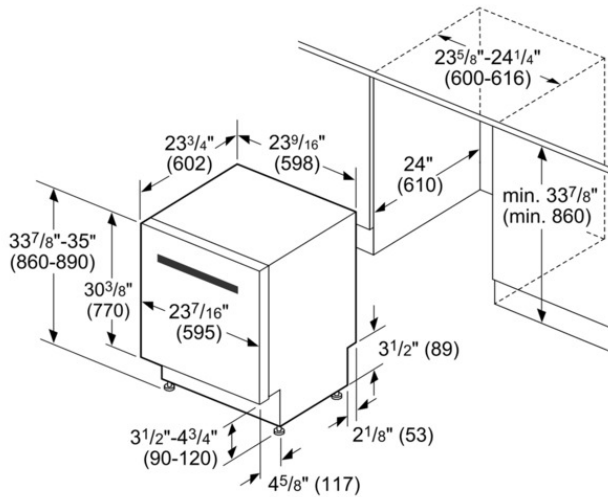

measurements in inches (mm)

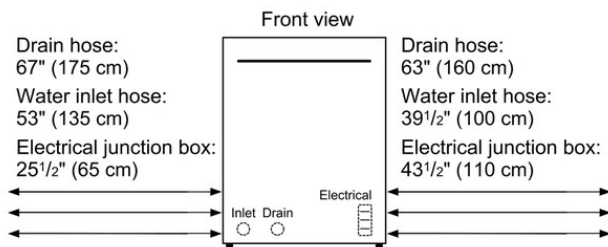

All connections are at the rear of the appliance.
Extension for drain hose available as accessory.
Power cord for connection to electrical outlet (3-prong plug)
available as accessory.

Features

| | |
|---|---------------------------------|
| Watts (W) | 1300 |
| Current (A) | 12 |
| Volts (V) | 120 |
| Frequency (Hz) | 60 |
| Power Cord Length | 43 1/2" |
| Minimum Water Pressure (lb/sin) | 14.0 |
| Length inlet hose (in) | 53" |
| Length outlet hose (in) | 67 " |
| Overall appliance dimensions (HxWxD) (in) | 33 7/8 " x 23 9/16 " x 23 3/4 " |
| Required cutout size (HxWxD) (in) | 33 7/8 " x 23 5/8 " x 24 " |
| Adjustable feet | Yes |

Technical Specification

| | |
|---------------------------------------|-----------------|
| Number of wash cycles | 5 |
| Number of options | 5 |
| Third Rack | 3rd Rack 1.0 |
| Tub material | Stainless steel |
| Concealed heating element | Yes |
| Leak protection system | Yes |
| Five-level wash | Yes |
| Water softener | No |
| ChildLock | No |
| Total annual energy consumption (kWh) | 259 |
| Energy Efficiency Class | Tier 1 |
| Energy Star® qualified | Yes |
| Total annual energy consumption (kWh) | 623.5 |
| Total annual water consumption (g) | 624 |
| Number of place settings | 15 |

Notes: All height, width and depth dimensions are shown in inches. *Please refer to installation instructions prior to making cutout. BSH reserves the absolute and unrestricted right to change product materials and specifications, at any time, without notice. Consult the product's installation instructions for final dimensional data and other details. Applicable product warranty can be found in a accompanying product literature or you may contact your account manager for further details.

For more information on our entire line of products, go to boschappliances.com or call 1-800-944-2904.

Copyright ©2013 BSH Home Appliances Corporation. All rights reserved. Bosch is a registered trademark of Robert Bosch GmbH.

Litho Date: 12/2013

