

BUILT-IN OVEN SAFETY

Your safety and the safety of others are very important.

We have provided many important safety messages in this manual and on your appliance. Always read and obey all safety messages.



This is the safety alert symbol.

This symbol alerts you to potential hazards that can kill or hurt you and others.

All safety messages will follow the safety alert symbol and either the word "DANGER" or "WARNING."

These words mean:

⚠ DANGER

You can be killed or seriously injured if you don't immediately follow instructions.

⚠ WARNING

You can be killed or seriously injured if you don't follow instructions.

All safety messages will tell you what the potential hazard is, tell you how to reduce the chance of injury, and tell you what can happen if the instructions are not followed.

INSTALLATION REQUIREMENTS

Tools and Parts

Gather the required tools and parts before starting installation. Read and follow the instructions provided with any tools listed here.

Tools needed

- Phillips screwdriver
- Measuring tape
- Hand or electric drill (for wall cabinet installations)
- 1" (2.5 cm) drill bit (for wall cabinet installations)
- Level
- Flat-blade screwdriver

Parts needed

- UL listed or CSA approved conduit connector
- UL listed wire connectors
- Warming Drawer Deflector Kit (for ovens installed above a warming drawer)
 - Order Part Number W10510613 for white 27" (68.6 cm) kit
 - Order Part Number W10531009 for black 27" (68.6 cm) kit
 - Order Part Number W10536338 for stainless steel 27" (68.6 cm) kit
 - Order Part Number W10510614 for white 30" (76.2 cm) kit
 - Order Part Number W10531010 for black 30" (76.2 cm) kit
 - Order Part Number W10536339 for stainless steel 30" (76.2 cm) kit
 - Order Part Number W10727416A for stainless steel/black 30" (76.2 cm) kit

To order, see the "Assistance or Service" section of the Use and Care Guide.

Parts supplied

- #8-14 x 1" screws - single ovens (2), double ovens (4)
- Two #8-18 x 3/8" screws - bottom vent
- Four #8-18 x 1/4" screws - bottom vent trim
- Four #8-18 x 3/8" screws - double oven feet
- Bottom vent
- Bottom vent trim
- Two rear feet - double oven
- Two front feet - double oven
- Foam strip - single oven*

Check local codes. Check existing electrical supply. See "Electrical Requirements."

It is recommended that all electrical connections be made by a licensed, qualified electrical installer.

*Foam strip not included with double oven.

Location Requirements

IMPORTANT: Observe all governing codes and ordinances.

- Cabinet opening dimensions that are shown must be used. Given dimensions provide minimum clearance with oven.
- Recessed installation area must provide complete enclosure around the recessed portion of the oven.
- Grounded electrical supply is required. See "Electrical Requirements" section.

- Electrical supply junction box should be located 3" (7.6 cm) maximum below the support surface when the oven is installed in a wall cabinet. A 1" (2.5 cm) minimum diameter hole should have been drilled in the right rear or left rear corner of the support surface to pass the appliance cable through to the junction box.

NOTE: For undercounter installation, it is recommended that the junction box be located in the adjacent right or left cabinet. If you are installing the junction box on rear wall behind oven, it is recommended that the junction box be recessed and located in the upper center of the cabinet.

- Oven support surface must be solid, level and flush with bottom of cabinet cutout.
- Floor must be able to support a single oven weight of 129 lbs (59 kg) for 27" (68.6 cm) models or 154 lbs (70 kg) for 30" (76.2 cm) models.
- Floor must be able to support a double oven weight of 251 lbs (114 kg) for 27" (68.6 cm) models or 288 lbs (131 kg) for 30" (76.2 cm) models.

IMPORTANT: To avoid damage to your cabinets, check with your builder or cabinet supplier to make sure that the materials used will not discolor, delaminate or sustain other damage. This oven has been designed in accordance with the requirements of UL and CSA International and complies with the maximum allowable wood cabinet temperatures of 194°F (90°C).

Undercounter Installation (with cooktop installed above):

Ovens approved for this type of installation have an approval label located on the top of the oven. Refer to Cutout Dimensions For Ovens Installed Under Cooktop (separate sheet).

Cabinet Dimensions - Single Ovens

Single Oven Undercounter (without cooktop installed above)

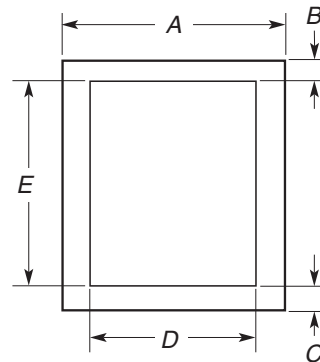

27" (68.6 cm) models

- A. 27" (68.6 cm) min. cabinet width
- B. 1 1/2" (3.8 cm) min. top of cutout to underside of countertop
- C. 5 1/4" (13.3 cm) bottom of cutout to floor
- D. 25 1/2" (64.8 cm) cutout width
- E. 28" (71.2 cm) min. cutout height

30" (76.2 cm) models

- A. 30" (76.2 cm) min. cabinet width
- B. 1 1/2" (3.8 cm) min. top of cutout to underside of countertop
- C. 5 1/4" (13.3 cm) bottom of cutout to floor
- D. 28 1/2" (72.4 cm) cutout width
- E. 28" (71.2 cm) min. cutout height

Single Ovens Installed in Cabinet

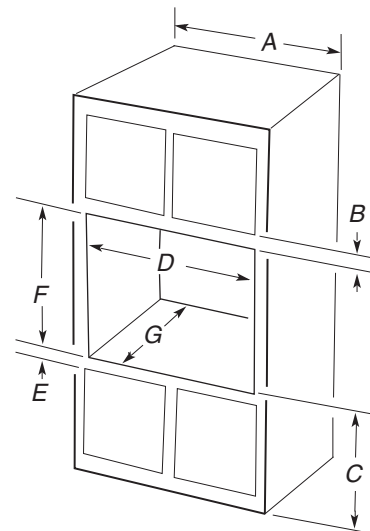

27" (68.6 cm) models

- A. 27" (68.6 cm) min. cabinet width
- B. 1" (2.5 cm) top of cutout to bottom of upper cabinet door
- C. 32" (81.3 cm) bottom of cutout to floor
- D. 25 1/2" (64.8 cm) cutout width
- E. 1 1/2" (3.8 cm) min. bottom of cutout to top of cabinet door
- F. 28" (71.2 cm)* recommended cutout height
- G. 24" (60.7 cm) cutout depth

30" (76.2 cm) models

- A. 30" (76.2 cm) min. cabinet width
- B. 1" (2.5 cm) top of cutout to bottom of upper cabinet door
- C. 32" (81.3 cm) bottom of cutout to floor
- D. 28 1/2" (72.4 cm) cutout width
- E. 1 1/2" (3.8 cm) min. bottom of cutout to top of cabinet door
- F. 28" (71.2 cm)* recommended cutout height
- G. 24" (60.7 cm) cutout depth

***NOTE:** The cutout height can be between 26 15/16" (68.4 cm) and 29 7/16" (74.8 cm) for single ovens.

Product Dimensions - Single Ovens

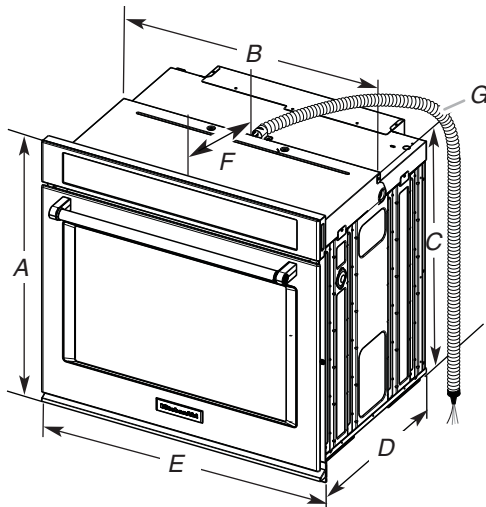

27" (68.6 cm) models

- A. 28 3/4" (72.8 cm) max. overall height
- B. 25 7/16" (64.6 cm) max. recessed width
- C. 26 3/4" (67.9 cm) recessed height
- D. 23 1/4" (59.1 cm) max. recessed depth
- E. 27" (68.6 cm) overall width
- F. 12" (30.5 cm) from back of control panel to start of strain relief
- G. 48" (121.9 cm) flexible conduit length

30" (76.2 cm) models

- A. 28 3/4" (72.8 cm) max. overall height
- B. 28 1/2" (72.4 cm) max. recessed width
- C. 26 3/4" (67.9 cm) recessed height
- D. 23 1/4" (59.1 cm) max. recessed depth
- E. 30" (76.2 cm) overall width
- F. 12" (30.5 cm) from back of control panel to start of strain relief
- G. 48" (121.9 cm) flexible conduit length

Product Dimensions - Double Ovens

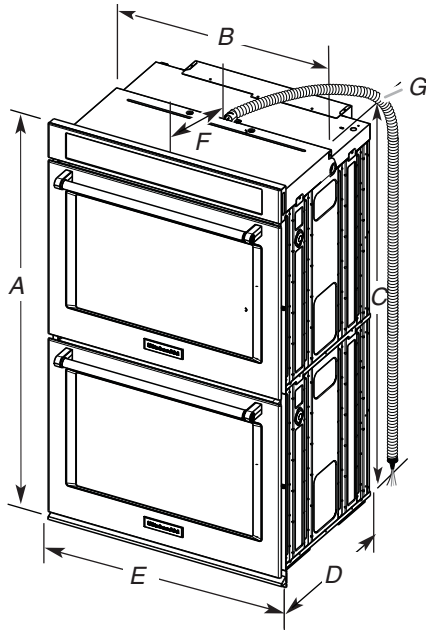

27" (68.6 cm) models

- A. 51 ³/₁₆" (130.0 cm) max. overall height
- B. 25 ⁷/₁₆" (64.6 cm) max. recessed width
- C. 48 ¹³/₁₆" (124.0 cm) recessed height
- D. 23 ¹/₄" (59.1 cm) max. recessed depth
- E. 27" (68.6 cm) overall width
- F. 12" (30.5 cm) from back of control panel to start of strain relief
- G. 66" (167.6 cm) flexible conduit length

30" (76.2 cm) models

- A. 51 ³/₁₆" (130.0 cm) max. overall height
- B. 28 ¹/₂" (72.4 cm) max. recessed width
- C. 48 ¹³/₁₆" (124.0 cm) recessed height
- D. 23 ¹/₄" (59.1 cm) max. recessed depth
- E. 30" (76.2 cm) overall width
- F. 12" (30.5 cm) from back of control panel to start of strain relief
- G. 66" (167.6 cm) flexible conduit length

Cabinet Dimensions - Double Ovens

Double Ovens Installed in Cabinet

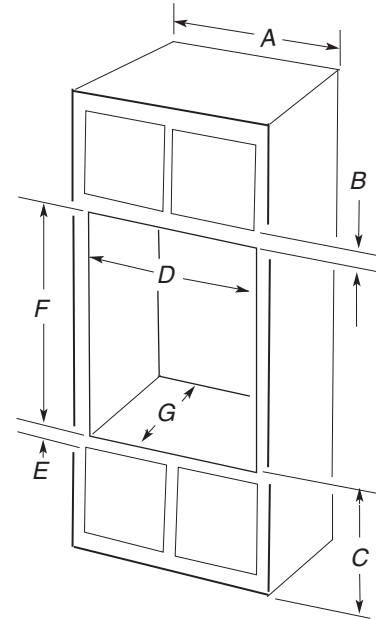

27" (68.6 cm) models

- A. 27" (68.6 cm) min. cabinet width
- B. 1" (2.5 cm) top of cutout to bottom of upper cabinet door
- C. 14 ³/₄" (37.5 cm) bottom of cutout to floor is recommended. 4"-14 ³/₄" (10.2-37.5 cm) bottom of cutout to floor is acceptable.
- D. 25 ¹/₂" (64.8 cm) cutout width
- E. 1 ¹/₂" (3.8 cm) min. bottom of cutout to top of cabinet door
- F. 50 ¹/₄" (127.6 cm)* recommended cutout height
- G. 24" (60.7 cm) cutout depth

30" (76.2 cm) models

- A. 30" (76.2 cm) min. cabinet width
- B. 1" (2.5 cm) top of cutout to bottom of upper cabinet door
- C. 14 ³/₄" (37.5 cm) bottom of cutout to floor is recommended. 4"-14 ³/₄" (10.2-37.5 cm) bottom of cutout to floor is acceptable.
- D. 28 ¹/₂" (72.4 cm) cutout width
- E. 1 ¹/₂" (3.8 cm) min. bottom of cutout to top of cabinet door
- F. 50 ¹/₄" (127.6 cm)* recommended cutout height
- G. 24" (60.7 cm) cutout depth

***NOTE:** The cutout height can be between 48 ⁷/₈" (124.1 cm) and 52 ³/₁₆" (132.6 cm) for double ovens.

Electrical Requirements

If codes permit and a separate ground wire is used, it is recommended that a qualified electrical installer determine that the ground path and the wire gauge are in accordance with local codes.

Check with a qualified electrical installer if you are not sure the oven is properly grounded.

This oven must be connected to a grounded metal, permanent wiring system.

Be sure that the electrical connection and wire size are adequate and in conformance with the National Electrical Code, ANSI/NFPA 70-latest edition or CSA Standards C22.1-94, Canadian Electrical Code, Part 1 and C22.2 No. O-M91-latest edition, and all local codes and ordinances.

A copy of the above code standards can be obtained from:

National Fire Protection Association
1 Batterymarch Park
Quincy, MA 02169-7471

CSA International
8501 East Pleasant Valley Road
Cleveland, OH 44131-5575

Electrical Connection

To properly install your oven, you must determine the type of electrical connection you will be using and follow the instructions provided for it here.

- Oven must be connected to the proper electrical voltage and frequency as specified on the model/serial number rating plate. The model/serial number rating plate is located under the control panel on single ovens and under the control panel on the upper oven cavity on double ovens. See the following illustrations.

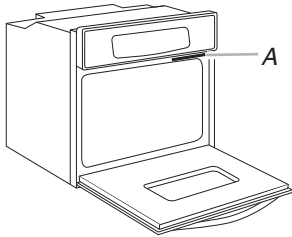

Single Oven

A. Model/serial number plate

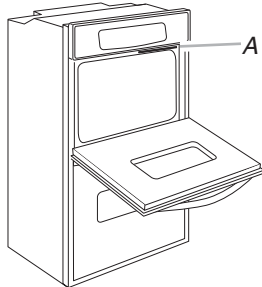

Double Oven

A. Model/serial number plate

- Models rated from 7.3 to 9.6 kW at 240 volts (5.4 to 7.4 kW at 208 volts) require a separate 40-amp circuit. Models rated at 4.8 kW and below at 240 volts (3.6 kW and below at 208 volts) require a separate 20-amp circuit.
- A circuit breaker is recommended.
- Connect directly to the circuit breaker box (or fused disconnect) through flexible, armored or nonmetallic sheathed, copper cable (with grounding wire). See “Make Electrical Connection” section.
- Flexible conduit from the oven should be connected directly to the junction box.
- Fuse both sides of the line.
- Do not cut the conduit. The length of conduit provided is for serviceability of the oven.
- A UL listed or CSA approved conduit connector must be provided.
- If the house has aluminum wiring, follow the procedure below:
 1. Connect a section of solid copper wire to the ends of the flexible conduit leads.
 2. Connect the aluminum wiring to the added section of copper wire using special connectors and/or tools designed and UL listed for joining copper to aluminum.

Follow the electrical connector manufacturer's recommended procedure. Aluminum/copper connection must conform with local codes and industry accepted wiring practices.

For power requirements for models KOST107E, KOST100E, KOSE507E, KOSE500E, KODE307E, KODE300E, KODE507E and KODE500E, refer to the following table.

Voltage	Single Thermal	Single Convect	Double Thermal	Double Convect	Double Convect/Thermal
240 VAC	4083 W	4141 W	8163 W	8279 W	8221 W
208 VAC	3088 W	3145 W	6172 W	6288 W	6230 W
240 VAC	17.4 A	17.8 A	34.7 A	35.7 A	35.2 A
208 VAC	15.1 A	15.6 A	30.2 A	31.2 A	30.7 A