

# 24" Panel Ready Dishwasher

## 800 Plus Series

### SHV7PT53UC



#### Features and Benefits

##### Key Features

- 42 dBA- Quietest Brand
- Flexible 3rd Rack with Adjustable Separators Provides Additional Loading Capacity
- Touch Control Technology
- TimeLight™ Beams Remaining Time of the Cycle on Floor
- Water Softener Ensures Perfect Shine

##### Design

- Full Size Stainless Steel Tall Tub Installs Perfectly Flush
- Flexible 3rd Rack with Adjustable Separators Provides Additional Loading Capacity
- 16 Place Setting Capacity
- LED Remaining Time Display
- Touch Control Technology
- RackMatic™ on Upper Rack - 3 Height Adjustments and Up to 9 Possible Rack Positions
- Flexible Silverware Basket Can be Split into Two Pieces and Placed Anywhere for Added Flexibility
- Extra Tall Item Sprinkler Cleans Items 22" Tall

##### Performance

- 42 dBA- Quietest Brand
- 6 Programs and 5 Options
- Detergent Tray Optimizes Detergent Dissolving
- Load Size Sensor Automates Wash Temperature
- Water Softener Ensures Perfect Shine
- Sanitize Option Eliminates Bacteria and Enhances Drying Results



Notes: All height, width and depth dimensions are shown in inches. \*Please refer to installation instructions prior to making cutout. BSH reserves the absolute and unrestricted right to change product materials and specifications, at any time, without notice. Consult the product's installation instructions for final dimensional data and other details. Applicable product warranty can be found in a accompanying product literature or you may contact your account manager for further details.

For more information on our entire line of products, go to [boschappliances.com](http://boschappliances.com) or call 1-800-944-2904.  
Copyright ©2013 BSH Home Appliances Corporation. All rights reserved. Bosch is a registered trademark of Robert Bosch GmbH.

Litho Date: 06/2013



# 24" Panel Ready Dishwasher

## 800 Plus Series

### SHV7PT53UC

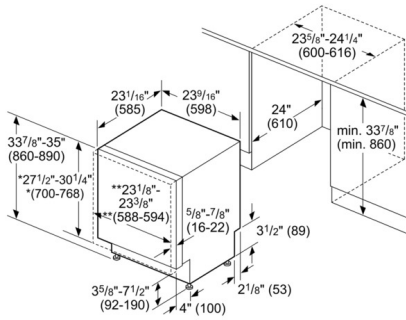

\* measured from the bottom edge of the countertop panel thickness recommended 3/4" (20 mm), panel weight 9-18 lb (4-8 kg)  
 \*\* 24" (610 mm) wide panel may be used depending on cabinet design

measurements in inches (mm)

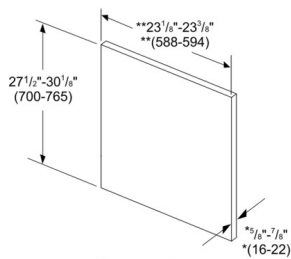

\* thickness recommended 3/4" (20 mm), panel weight 9-18 lb (4-8 kg)  
 \*\* 24" (610 mm) wide panel may be used depending on cabinet design

measurements in inches (mm)

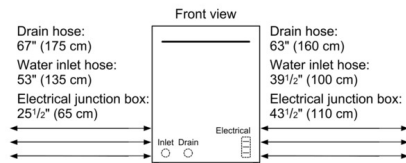

All connections at the rear of the appliance.  
 Extensions for drain hose available as accessory.  
 Electrical cable for outlet connection (3 pin plug) available as accessory.

### Features

Leak Protection System	
ChildLock	No
Water softener	Yes
Upper Rack	
Adjustable upper rack	Rackmatic 3-stage
Upper rack cup shelf	2
Lower Rack	
Lower rack cup shelf	
3rd Rack	3rd Rack 2.0
Silverware basket	Standard
Optional accessories	SGZ1005UC, SGZ1007UC, SGZ1010UC, SGZ9091UC, SHZ1008UC, SMZ5002UC, SMZPC002UC
Remaining Time Projection	Yes

### Technical Specification

UPC code	825225905011
Panel ready	Yes
Alternative colors available	
Silence level (dBA)	42
Watts (W)	1300
Current (A)	12
Volts (V)	120
Frequency (Hz)	60
Energy Consumption (kWh/yr)	259
Energy Star® qualified	Yes
NSF certified	Yes
Plug type	Fixed connection
Power cord length (in)	43 1/2"
Length outlet hose (in)	67 "
Length inlet hose (in)	53"
Required cutout size (HxWxD) (in)	33 7/8 " x 23 5/8 " x 24 "
Product packaging dimensions (HxWxD) (in)	35 3/4" x 26" x 29 5/16"
Net weight (lbs)	92
Gross weight (lbs)	102
Adjustable feet	Yes - front only
Tube material	Stainless steel
Tube type	TallTube
ADA Compliant	No

Notes: All height, width and depth dimensions are shown in inches. \*Please refer to installation instructions prior to making cutout. BSH reserves the absolute and unrestricted right to change product materials and specifications, at any time, without notice. Consult the product's installation instructions for final dimensional data and other details. Applicable product warranty can be found in a accompanying product literature or you may contact your account manager for further details.

For more information on our entire line of products, go to [boschappliances.com](http://boschappliances.com) or call 1-800-944-2904.  
 Copyright ©2013 BSH Home Appliances Corporation. All rights reserved. Bosch is a registered trademark of Robert Bosch GmbH.

Litho Date: 06/2013

